

HALLCO MFG. COMPANY, INC.

HALLCO LIVE FLOOR



OWNER MANUAL

6000 SERIES DRIVE UNIT

Hallco Mfg. Co., Inc., through continued research and development, brings state-of-the-art design to the live floor industry.

Hallco will custom design and build the hydraulic drive mechanism to fit your individual needs. The Hallco Live Floor systems lend themselves to many different conveyor applications. Whether for mobile or stationary operation, Hallco can supply the system to fulfill your needs.

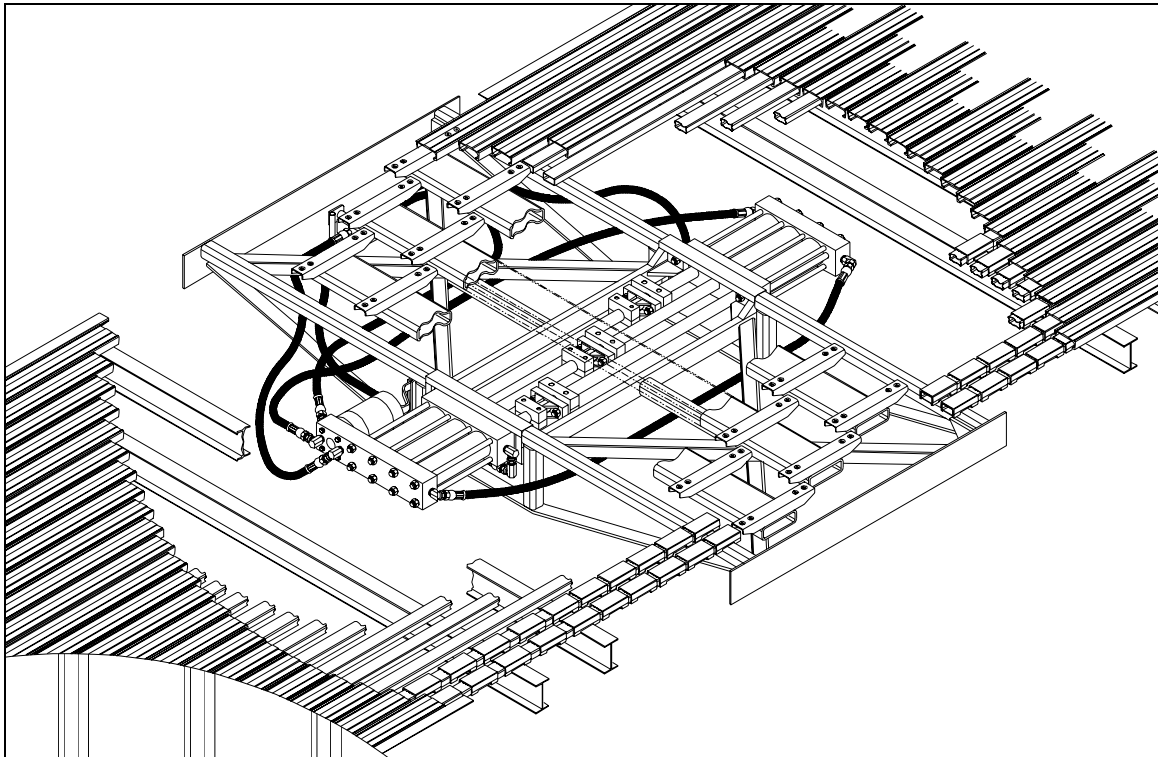

FEATURES:

- LIGHT WEIGHT.
- LOW MAINTENANCE.
- AVAILABLE IN ONE AND TWO WAY SYSTEMS.
- UNITIZED CONSTRUCTION EASING INSTALLATION.
- MODULAR DESIGN REDUCES THE NUMBER OF EXTERNAL FITTINGS REQUIRED.
- VARIABLE SPEED FOR CONTROLLED LOADING AND UNLOADING.

TABLE OF CONTENTS

TITLE	PAGE
How they work	3
6000 series hydraulic power unit requirements	4
Operation	6
Trouble shooting	8
Setting the control rod stops	10
Trouble shooting (cont.)	11
Theoretical unload times	13
Exploded assembly - Drive unit	14
Repairing unit - Seal placement	15
Repairing unit - Torqueing manifold bolts	16
6000 Two Way Plumbing	17
Switching valve break down	18
Deck bolt torques	19
Warranty	20

HALLCO MFG. COMPANY, INC.



HOW THEY WORK

The Hallco Live Floor is hydraulically operated. Six hydraulic cylinders mounted horizontally, provide the muscle to move the load. During operation, all deck slats move out together, moving the load with them.

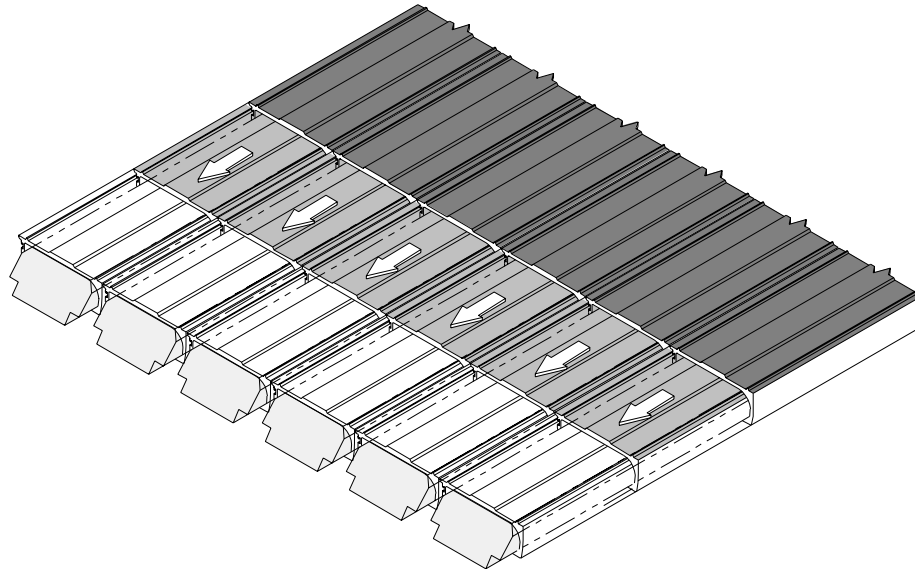

Then the deck slats return to their starting position sequentially, with every third slat moving in unison.

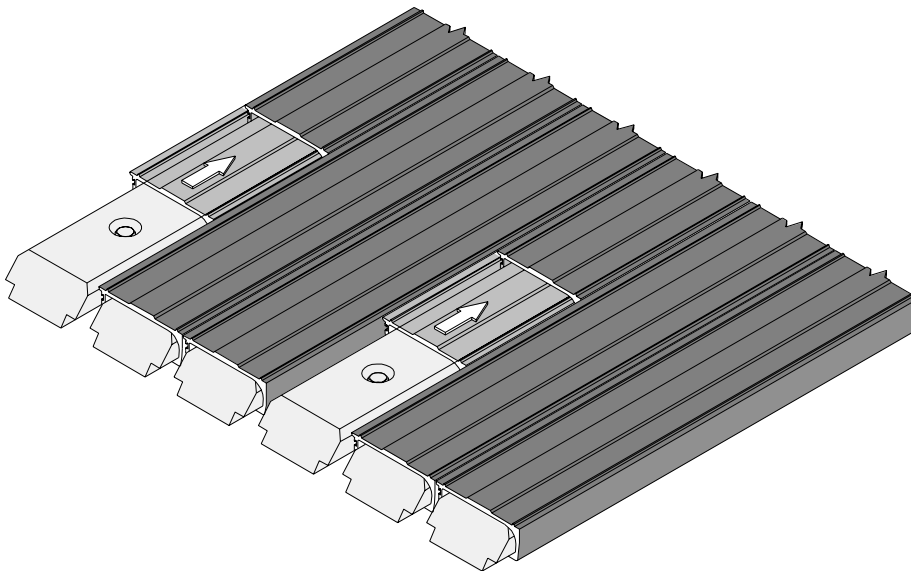

6000 SERIES HYDRAULIC POWER UNIT REQUIREMENTS

HALLCO RECOMMENDS CONSULTING A HYDRAULIC SPECIALIST TO MATCH THE “PTO” AND PUMP TO YOUR TRACTOR’S TRANSMISSION.

THE WET KIT MUST PROVIDE NOT LESS THAN 2800 PSI NOR MORE THAN 3000 PSI. THE FLOW RATE SHOULD MATCH THE JOB.

HYDRAULIC

RESERVOIR: 20 TO 30 GALLON MINIMUM CAPACITY

The hydraulic reservoir should have facilities to mount the relief valve and a return line filter. Both of these items must dump the oil into the reservoir below the low level line. Hallco suggests a down draft be installed in the reservoir on the return line to limit the turbulence. The pump supply oil should be taken from 1” to 2” above the bottom of the reservoir. This outlet should be screened or baffled, to prevent a whirlpool. The whirlpool could result in air being introduced into the system. A sight gauge or other means of visually checking oil level should be installed. **NOTE:** When operating in warmer climates a 30 gallon minimum capacity reservoir is preferred.

OIL: A GOOD GRADE OF HYDRAULIC OIL, CLIMATIZED TO YOUR AREA

FILLER CAP: BREATHER TYPE, WITH FILTER

HYDRAULIC

PUMP: 25 TO 30 GPM AT 1200 RPM

An industrial quality vane type pump such as the Vickers Model 25V or 35V is recommended. The supply line from the reservoir should be 1 1/2” ID minimum. The supply line from the pump should be no smaller than 1” two wire type (Example Weatherhead 425-16).

PTO: 100% OUTPUT WITH CAB MOUNTED AIR OR CABLE SHAFT

The PTO should be able to direct mount the pump. Therefore, a Bottom Mount will be necessary in most cases. Control of the PTO from the cab can be either a cable or air shift. A dash mounted indicator light is also needed.

RELIEF

VALVE: EXTERNAL, TANK MOUNTED, SET AT 2800 MINIMUM to 3000 MAXIMUM PSI

The relief valve must be able to handle the system oil flow. Set at 2800 to 3000 PSI.

FILTER: RETURN LINE, TANK MOUNTED, 25 MICRON, RATED AT 45-50 GPM MIN.

A return line filter with a nominal rating of 45 to 50 GPM and a paper element of 25 micron or finer is needed to assure clean oil and a long system life.

QUICK

CONNECTS: CAPABLE OF HANDLING SYSTEM OIL FLOW (30-40 GPM)

PRESSURE

GAUGE: 0 TO 5000 PSI GLYCERINE FILLED

HALLCO MFG. COMPANY, INC.

6000 SERIES WET KIT REQUIREMENTS



Example of a typical tractor wet kit.

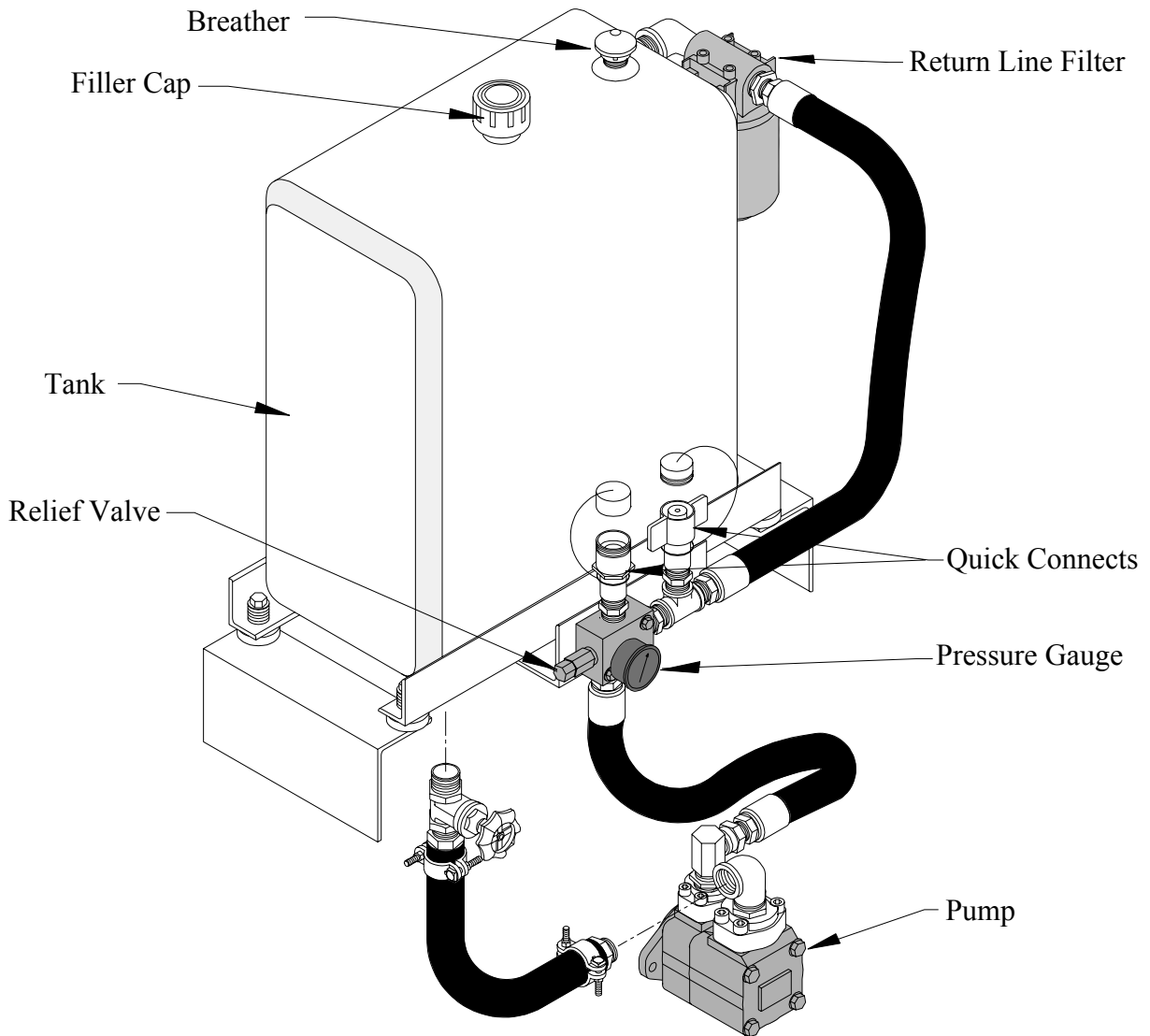

HALLCO MFG. COMPANY, INC.



OPERATION

Before initial start-up, inspect the entire unit. Check floor for improperly seated bearings and deck slats. Check front and rear of floor for proper end clearances (12" front & 14" rear). Check hydraulic fittings for tightness. Make sure the control rod on the switching valve is straight and that the stops are locked in place.

Check the hydraulic lines between the truck and trailer, making sure that they are fully connected and matched.

Check the live floor hand control valve, making sure that it is in the neutral position.

The hand control valve operation is illustrated below:

- UNLOAD MODE: Pull the handle all the way out
- NEUTRAL: Push handle in until it hits valve body
- LOAD MODE: Turn handle forward and push all the way in

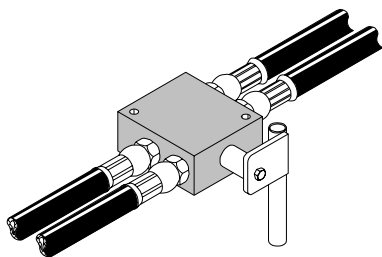

UNLOAD

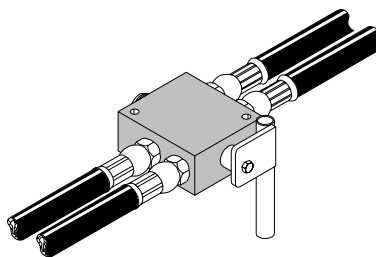

NEUTRAL

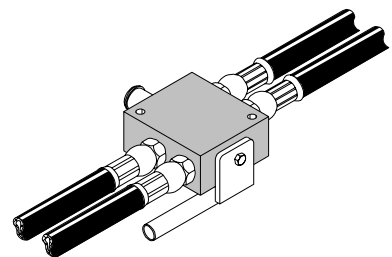

LOAD

Start the truck engine and engage the pump. Move the truck hydraulic valve to supply pressure to the trailer.

Pull the hand control valve on the trailer to the UNLOAD MODE (fully out) the floor will begin to move erratically at first, but after a few minutes should begin to sequence properly.

Allow the system to run steadily while checking floor. The floor should be allowed to run for about 30 minutes unladen.

OPERATION

NORMAL OPERATION IN UNLOAD MODE:

1. Drivers side cylinder shaft and forward-most crossdrive (Crossdrive #1) travel forward.
2. Center cylinder shaft and center crossdrive (Crossdrive #2) travel forward.
3. Curb side cylinder shaft and rear-most crossdrive (Crossdrive #3) travel forward.
4. All three cylinder shafts and all three crossdrives travel rearward in unison.

NORMAL OPERATION IN LOAD MODE:

1. Curb side cylinder shaft and rear-most crossdrive (Crossdrive #3) travel forward.
2. Center cylinder shaft and center crossdrive (Crossdrive #2) travel rearward.
3. Drivers side cylinder shaft and forward-most crossdrive (Crossdrive #1) travel rearward.
4. All three cylinder shafts and all three crossdrives travel forward in unison.

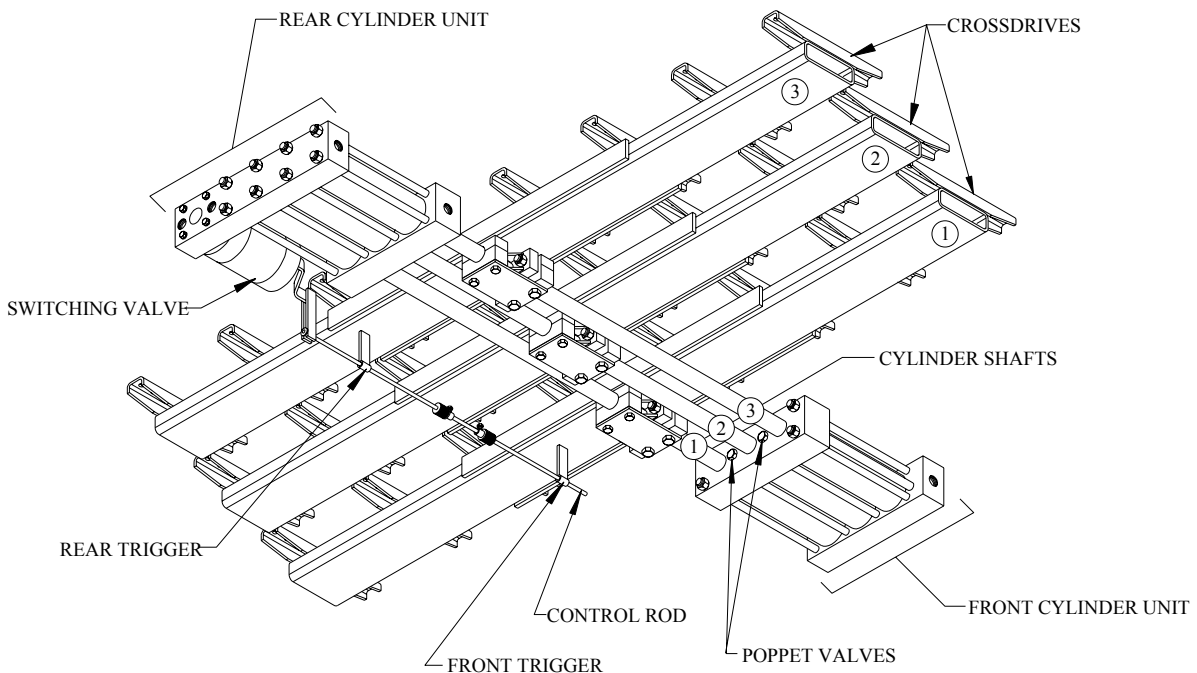

TROUBLE SHOOTING

Your Hallco Live Floor is designed for long trouble free operation.

The heart of the system is the hydraulic wet kit. The system requires a wet kit that will provide not less than 2800 PSI nor more than 3000 PSI.

Hallco recommends that you consult a hydraulic specialist to match the PTO and Pump to your truck's transmission.

Remember - Experience has shown that nearly all problems originate with the wet kit.

CHECK THE SIMPLE THINGS FIRST!

PROBLEM: Unit does not operate or operates slow.

- CHECK:**
- (A) PTO, is it fully engaged?
 - (B) OIL, is the oil reservoir full?
 - (C) QUICK CONNECTS, are they fully connected? Are they a matched set?
 - (D) PUMP, is the pump operating? Does it deliver 20-40 GPM at 2800-3000 PSI?
 - (E) RELIEF VALVE, is it set at 2800-3000 PSI?
 - (F) PLUMBING, is the entire system plumbed correctly?

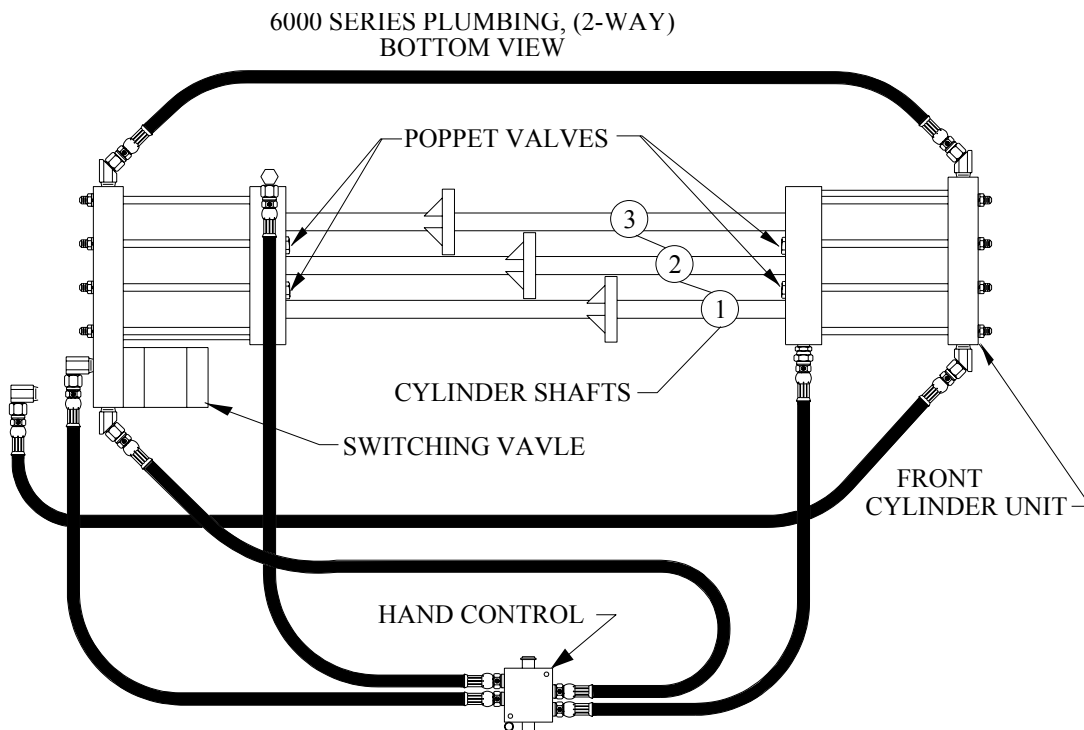

TROUBLE SHOOTING

IF ALL THE SIMPLE THINGS CHECK OUT, OK...

Disconnect the quick-connect on the pressure line to the Trailer. Engage the PTO and let the pump turn with the engine idling. The pressure gauge on the wet kit should read 2800 PSI with the engine idling.

PRESSURE GAUGE

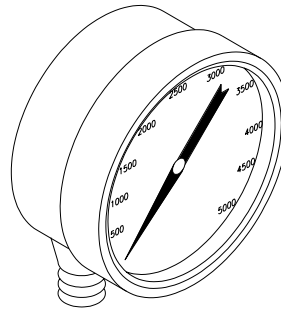

IF IT DOES, THE POWER UNIT IS OK.

IF IT DOES NOT, the pump or the relief valve needs servicing. If the pump **ONLY** becomes hot, that is the culprit. If the relief valve becomes hot, it may be defective, or have debris holding it partially open.

One clue to a bad pump, is having to rev up the engine to get enough pressure to operate the Unit.

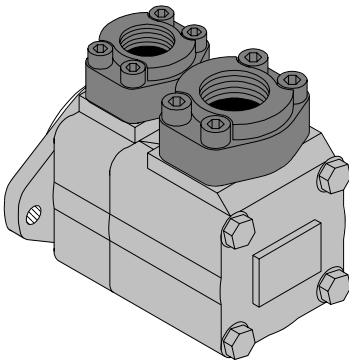

PUMP

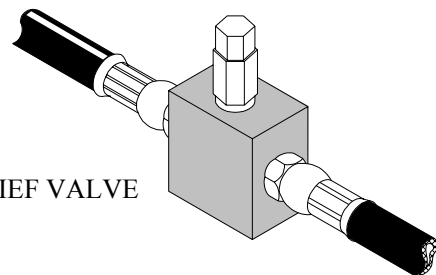

RELIEF VALVE

THE POWER UNIT CHECKS OUT, OK... AND STILL NO ACTION...

CHECK: The Switching Valve Control Rod stops. Proper adjustment of the stops on the control rod will move the rod as far as possible.

SETTING THE CONTROL ROD STOPS

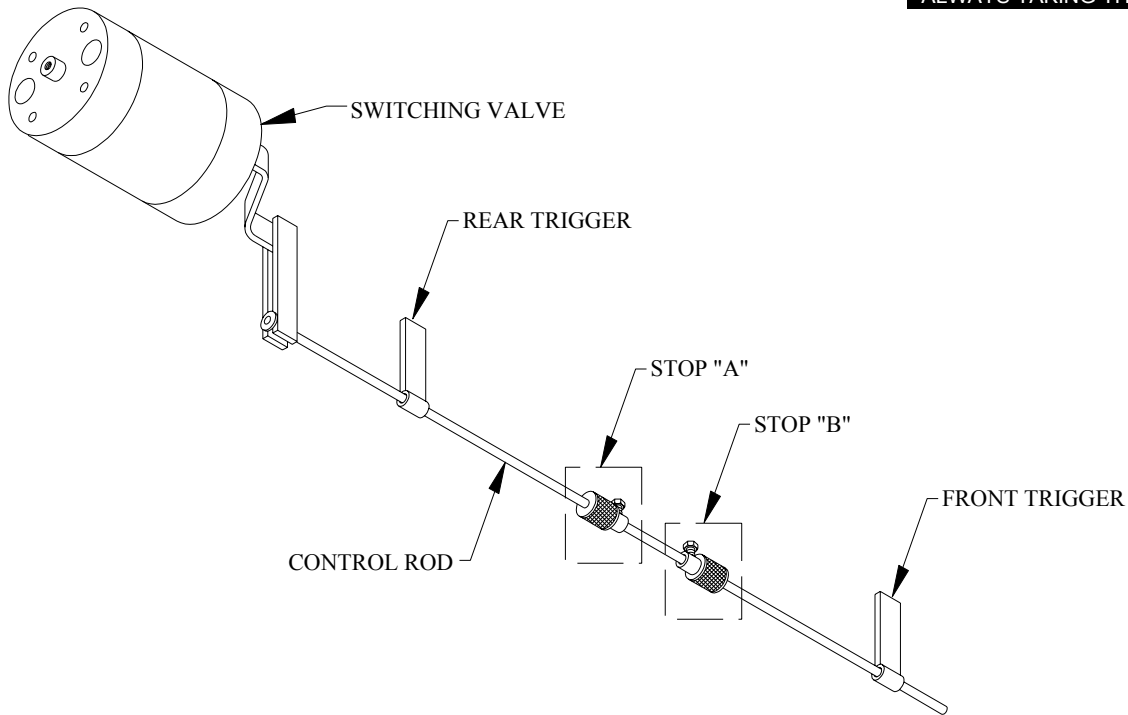

1. Release and move stops “A” and “B” away from the front and rear triggers.
2. Push the control rod rearward toward the switching valve until it stops.
3. Apply hydraulic pressure until rear cylinder shafts are fully extended, then shut off pressure.
4. Pull the control rod away from the switching valve until it stops. Move and set stop “A” firmly against the rear trigger.
5. Apply hydraulic pressure until the rear cylinder shafts are fully retracted, then shut off the pressure.
6. Push the control rod rearward toward the switching valve until it stops. Move and set stop “B” firmly against the front trigger.
7. Mark the position of the stops “A” and “B” on the control rod.
8. Apply hydraulic pressure to the cylinders until triggers are free of the stops. Shut off the pressure. Move stop “A” $\frac{3}{8}$ ” toward the rear trigger and tighten firmly. Move stop “B” $\frac{3}{8}$ ” toward the front trigger and tighten firmly.

TROUBLE SHOOTING

THE SWITCHING VALVE CONTROL ROD STOPS ARE ADJUSTED PROPERLY AND STILL NO ACTION...

CHECK: The switching valve temperature. If it becomes very hot, but the cylinders do not, there may have been some debris pass through the oil and damage this valve.

If only the hydraulic cylinders become hot, there may be a failure there.

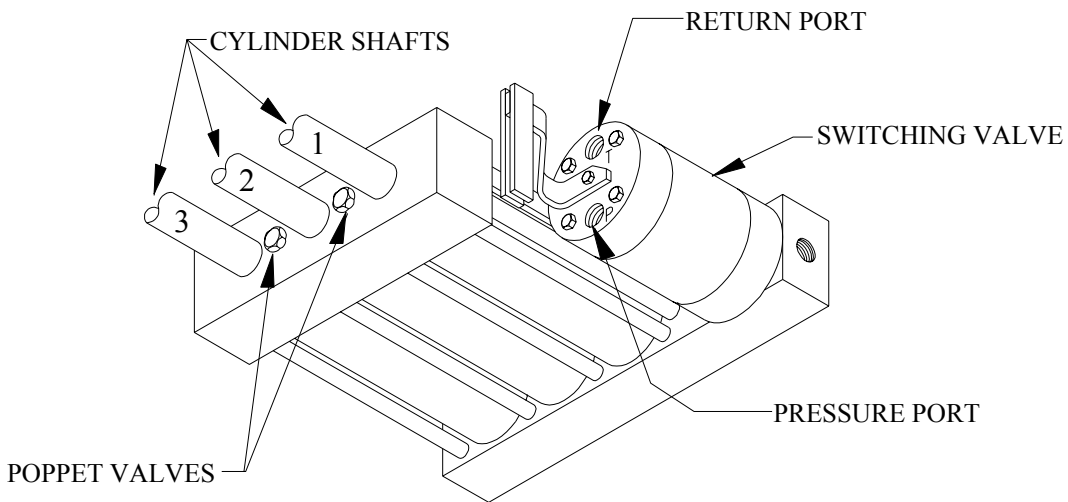

BOTTOM VIEW - REAR CYLINDER UNIT

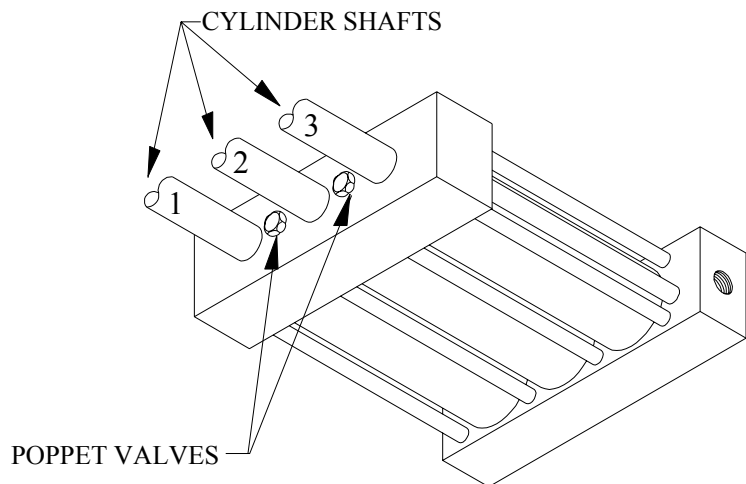

BOTTOM VIEW -FRONT CYLINDER UNIT

HALLCO MFG. COMPANY, INC.



TROUBLE SHOOTING

THE SYSTEM OPERATES AS IT SHOULD EXCEPT WHEN SEQUENCING...

CHECK: The cylinder barrels temperature. If one or more become very hot, then you are experiencing oil by-pass. Replace seals.

CHECK: The hand control valve temperature. If it becomes very hot, then you are experiencing oil by-pass there. Replace valve.

NO HEAT BUILD UP... AND STILL HAVING PROBLEMS...

SEQUENCING IN UNLOAD MODE:

PROBLEM: Crossdrive #1 and #2 travel forward together.

CHECK: Poppet valve located between cylinder shafts #1 and #2 in rear cylinder unit.

PROBLEM: Crossdrive #2 and #3 travel forward together.

CHECK: Poppet valve located between cylinder shafts #2 and #3 in rear cylinder unit.

SEQUENCING IN LOAD MODE:

PROBLEM: Crossdrive #2 and #3 travel rearward together.

CHECK: Poppet valve located between cylinder shafts #2 and #3 in front cylinder unit.

PROBLEM: Crossdrive #1 and #2 travel rearward together.

CHECK: Poppet valve located between cylinder shafts #1 and #2 in front cylinder unit.

CHECKING POPPET VALVES...

When one of the sequencing problems listed above occurs, it is usually caused by debris preventing the poppet valve from seating properly. To correct this, remove the poppet valve body and spring, replace the cap and cycle the system a few times. This should flush the debris through the system to be stopped at the filter.

IF ALL THESE THINGS HAVE NOT RESTORED FULL AND CORRECT FLOOR OPERATION, CONTACT YOUR DEALER OR CALL HALLCO MANUFACTURING AT 1-800-5-HALLCO

HALLCO MFG. COMPANY, INC.

THEORETICAL UNLOADING TIMES

FOR 45'-0" TRAILER



These times are approximate and should be used ONLY as a guide!!!
Breakdown of material will extend unloading time.

Error! Not a valid link.

⚡ ⚡ ⚡ ⚡ ⚡ ⚡ ⚡ ⚡ ⚡ ⚡ ⚡ ⚡ **IMPORTANT SERVICE TIPS** ⚡ ⚡ ⚡ ⚡ ⚡ ⚡ ⚡ ⚡ ⚡ ⚡ ⚡

During the first few weeks of operation, it will be necessary to frequently check and tighten all deck bolts to 35 ft/lbs for 3/8" bolts and 55 ft/lbs for 1/2" bolts. Eventually the bolts should remain tight. However, they should be checked occasionally to insure that they have not worked loose. Loose deck bolt will cause serious damage to the deck slats.

After the first week of operation you must check and tighten the cylinder tie bolts to 120 ft/lbs.

Change the filter element after the first 50 hours of operation and every 250 hours thereafter.

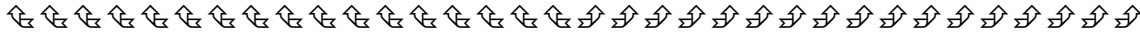

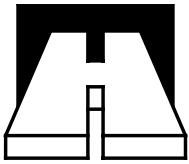

HALLCO FLOOR SYSTEMS

HALLCO LIVE FLOOR 6000 SERIES DRIVE UNIT

ALWAYS TAKING THE FIRST STEP™

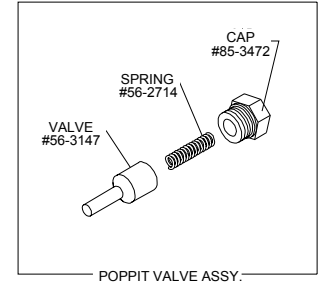
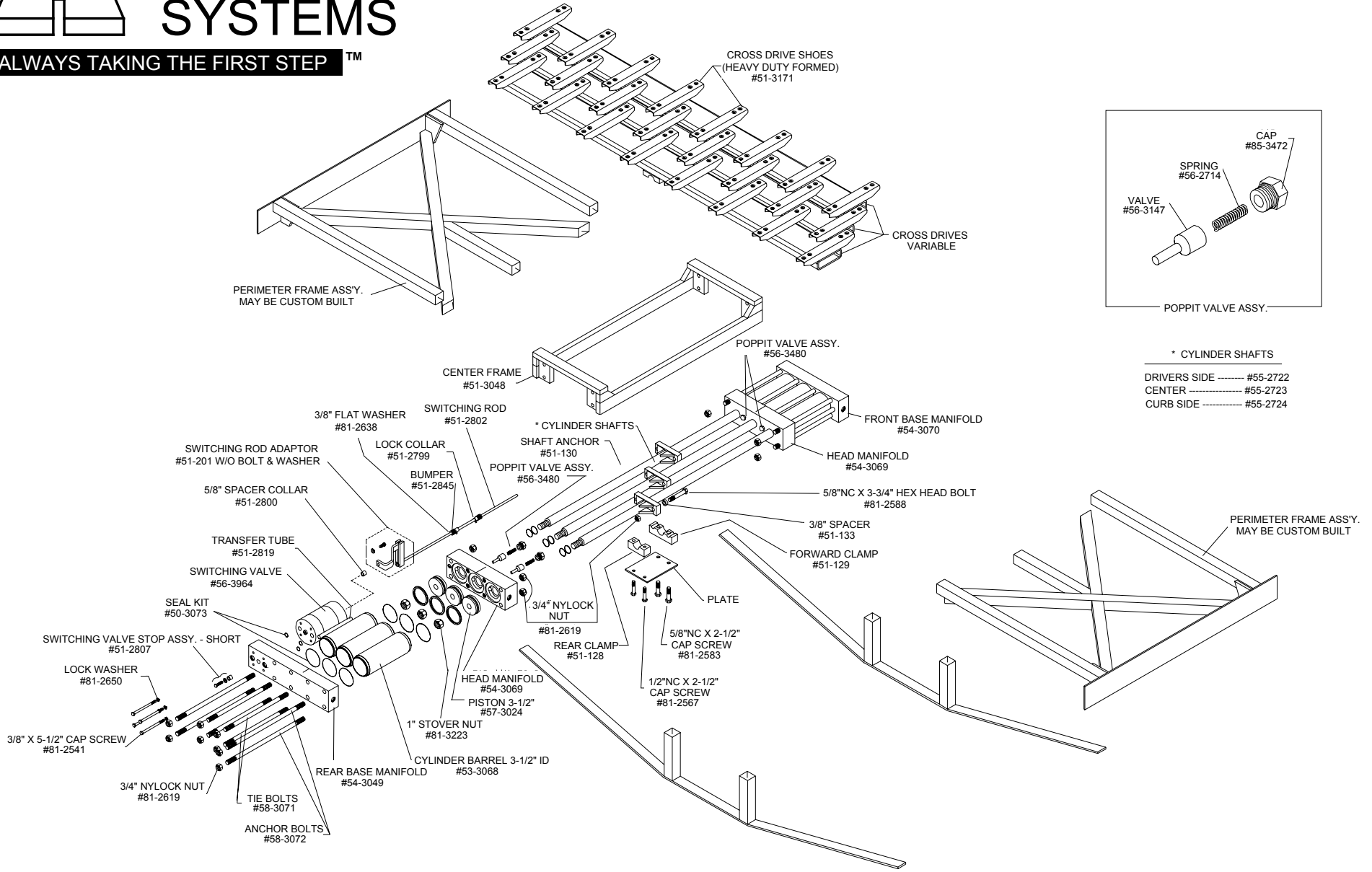

- * CYLINDER SHAFTS
- DRIVERS SIDE #55-2722
 - CENTER #55-2723
 - CURB SIDE #55-2724

COVERED BY: U.S. Patent Nos. 4143760, 4144963, 4184587, 4691819;
 CANADA Patent Nos. 901512, 1091611, 1094968; BRITISH Patent Nos. 1255318; GB 2 039 26;
 AUSTRALIAN Patent Nos. 527790; JAPAN Patent No. 736350.
 Other U.S. and foreign patents are pending.

MANUFACTURING: HALLCO MFG. COMPANY, INC. P.O. Box 505, Tillamook, OR 97141 Phone: Toll Free (800) 5-HALLCO or (503) 842-8886, Fax: (503) 842-8499
 HALLCO EAST/DISTRIBUTION: 606-B Performance Road, Mooresville, NC 28115 Phone (800) 230-0190, Fax (704) 662-9603

**REPAIRING UNIT
SEAL PLACEMENT**

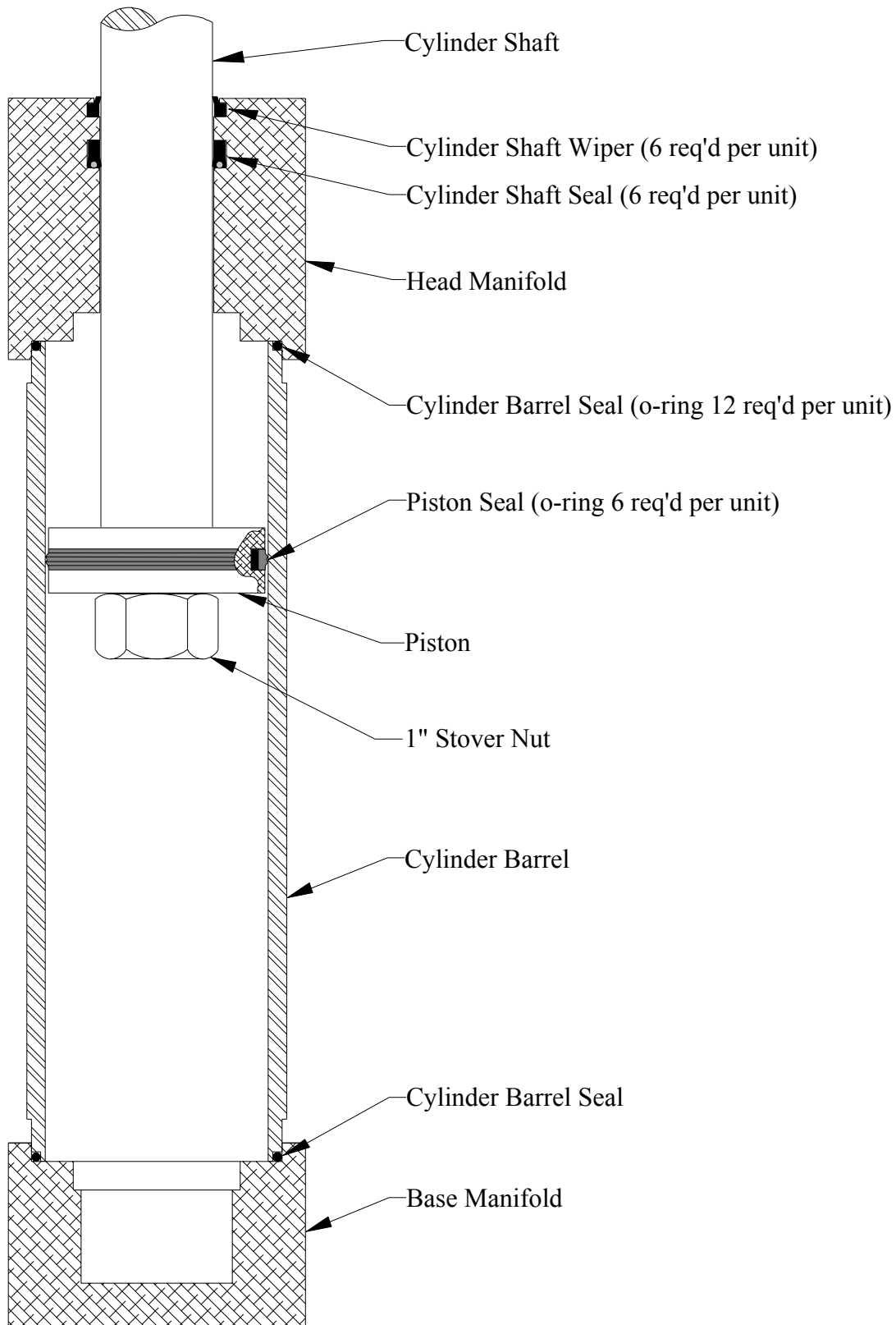

REPAIRING UNIT TORQUEING MANIFOLD BOLTS

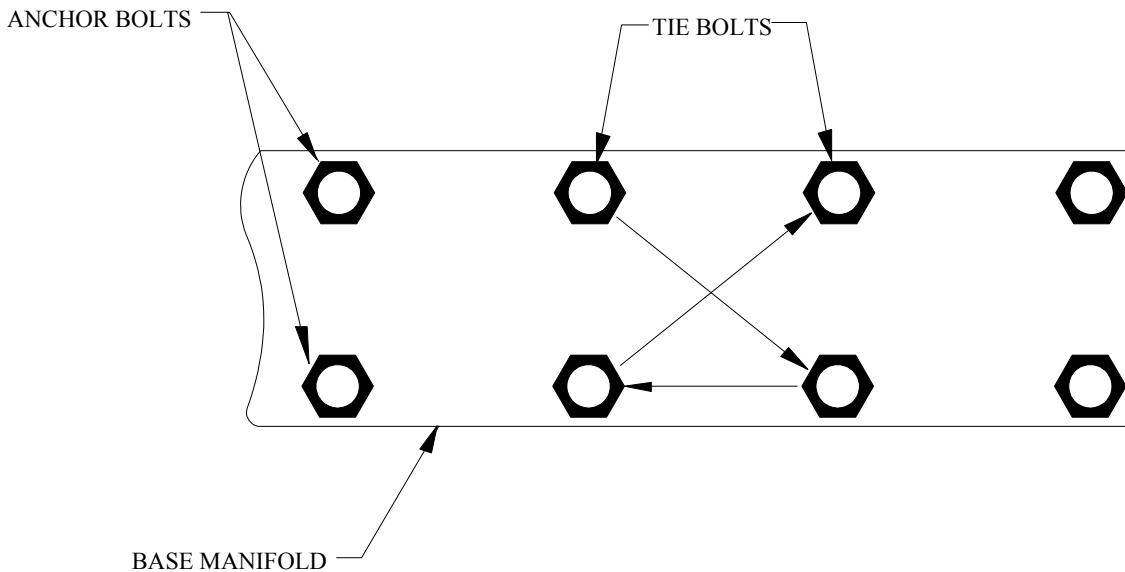

Starting with the center nuts (Tie Bolts) bring them up snug. Snug up the outer nuts (Anchor Bolts) as well. Now begin to torque down the center nuts (Tie Bolts) using a criss cross pattern. Bring these nuts to 120 ft/lbs. When the tie bolts are to the proper torque, bring the outer nuts (Anchor Bolts) to 120 ft/lbs torque using a criss cross pattern.

TORQUEING PISTON NUTS

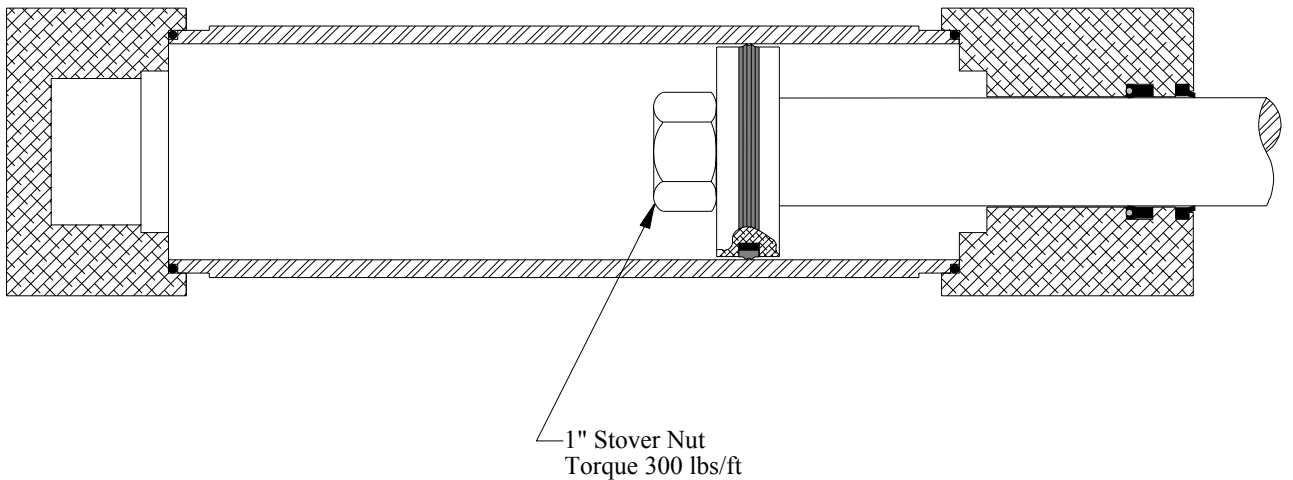

HALLCO MFG. COMPANY, INC.

6000 TWO WAY PLUMBING, STANDARD UNIT

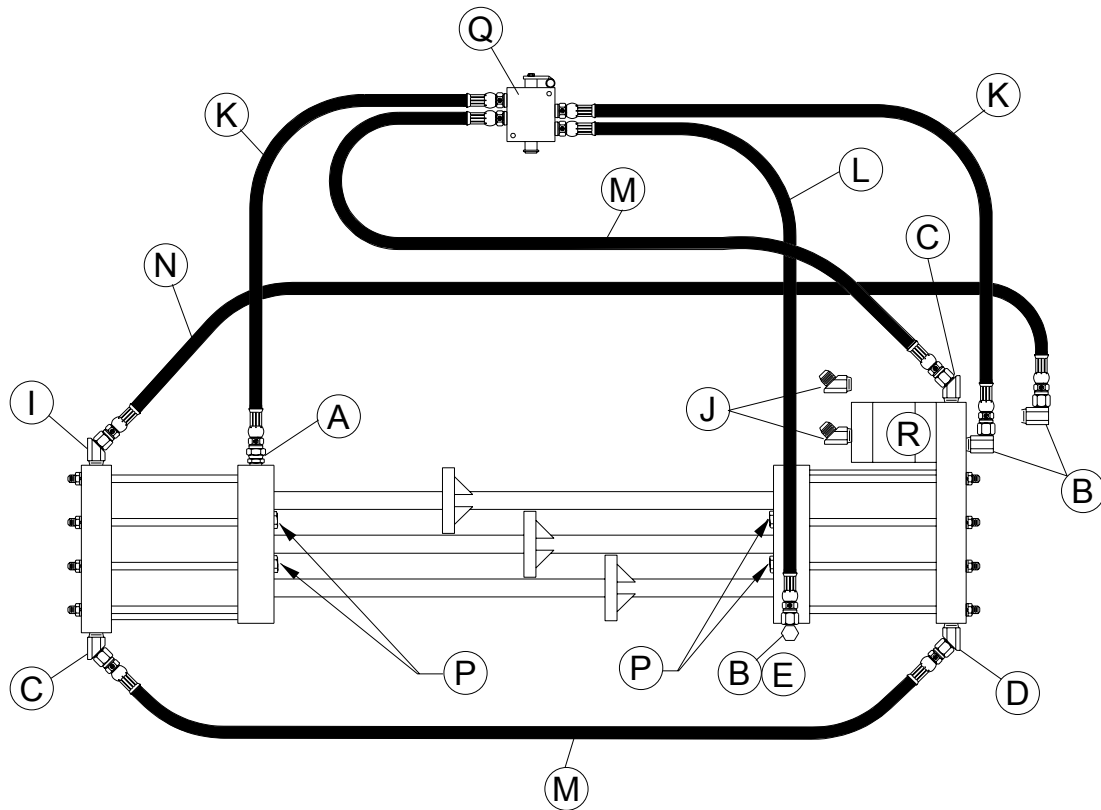

KEY LETTER	NO. REQ	PART NO.	DESCRIPTION
A	1	85-2661	ST SWIVEL FITTING, 3/4"MP - 3/4" FP
B	3	85-2662	90 SWIVEL FITTING, 3/4"MP - 3/4"FP
C	2	85-2663	45 SWIVEL FITTING, 3/4"MP - 3/4"FP
D	1	85-2667	45 STREET FITTING, 3/4"MP - 3/4"FP
E	1	85-2666	90 STREET ELBOW, 3/4"MP - 3/4"FP
I	1	85-2668	45 DEGREE ELBOW, 3/4"MP - 3/4JIC
J	2	85-3947	45 DEGREE ELBOW, 3/4"M ORING - 1"M JIC
K	2	86-2696	HOSE ASSY, MB480-12 48", 3/4" MP ENDS
L	1	86-2697	HOSE ASSY, MB600-12 60", 3/4" MP ENDS
M	2	86-2698	HOSE ASSY, MB720-12 72", 3/4" MP ENDS
N	1	86-2699	HOSE ASSY, MB900-12 90", 3/4" MP -3/4" FJICsw
P	4	85-3472	POPPET VALVE CAP
	4	56-2714	POPPET VALVE SPRING
	4	56-3147	POPPET VALVE
Q	1	56-3632	2-WAY ON/OFF VALVE (replaces 56-2718)
R	1	56-3964	SWITCHING VALVE, with O-ring ports

HALLCO MFG. COMPANY, INC.

SWITCHING VALVE BREAKDOWN

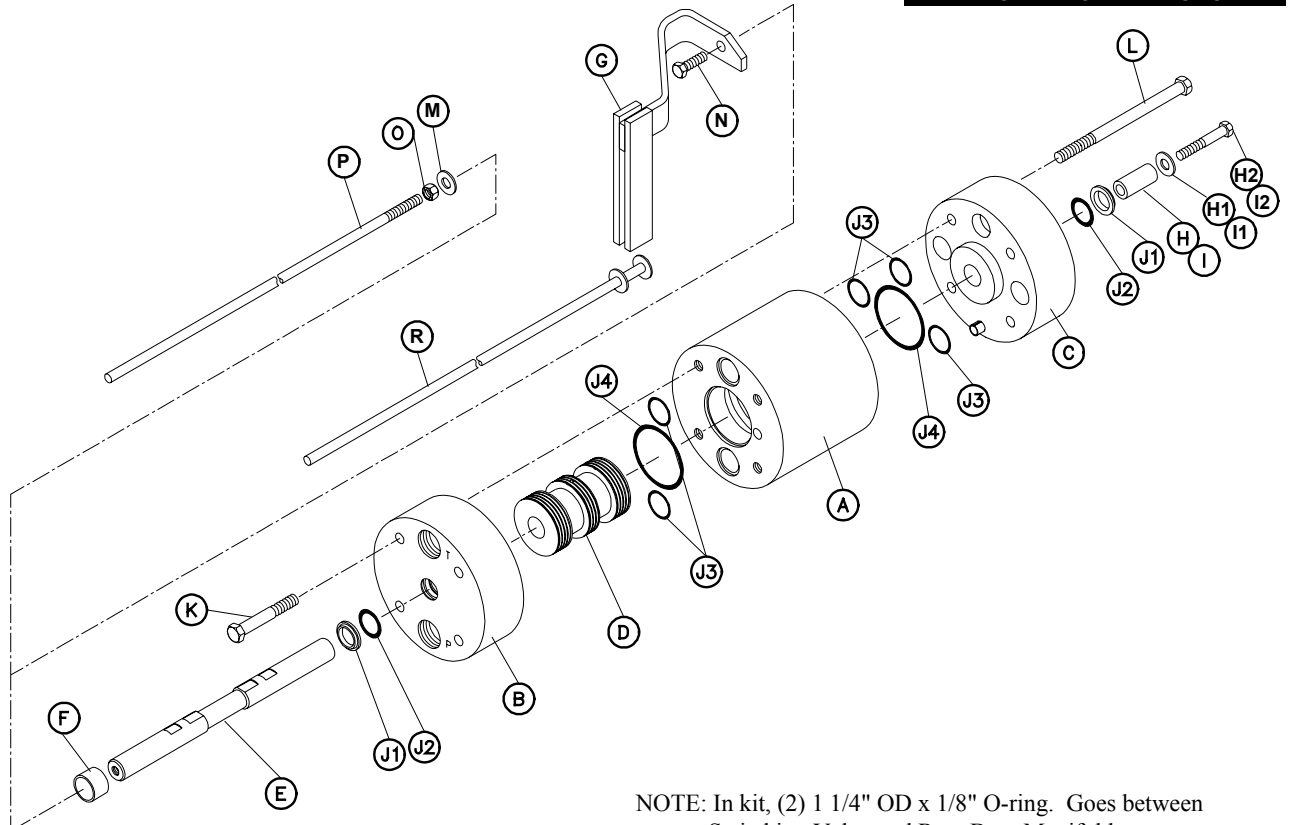

NOTE: In kit, (2) 1 1/4" OD x 1/8" O-ring. Goes between Switching Valve and Rear Base Manifold.

ITEM	PART NO.	DESCRIPTION	SIZE	NOTES	REQD
A		VALVE BODY			1
B		FORWARD ENDCAP			1
C		REAR END CAP			1
D		VALVE SPOOL			1
E		VALVE PILOT ROD			1
F	51-2800	SPACER COLLAR	5/8" LONG		1
G	51-201	DOG LEG ADAPTER		PERIMETER FRAME UNITS	1
H	51-2808	LONG STOP ASSEMBLY	3/8" x 1 7/8" SPACER	BEFORE 1987	1
H1	81-2638	FLAT WASHER	3/8"		1
H2	81-2515	CAP SCREW	5/16" NC x 2"	USE WITH 1 3/8" SPACER	1
I	51-2807	SHORT STOP ASSEMBLY	3/8" x 1 3/8" SPACER	AFTER 1987	1
I1	81-2638	FLAT WASHER	3/8"		1
I2	81-2513	CAP SCREW	5/16" NC x 2 1/2"	USE WITH 1 7/8" SPACER	1
J	51-2709	SEAL KIT		#959-5	
J1		WIPER		SECTION #2-210N674	2
J2		O-RING	1" OD x 1/8"	SECTION #2-117N674	2
J3		O-RING	1" OD x 3/32"	SECTION #2-136N674	5
J4		O-RING	2 3/16" OD x 3/32"		2
K	81-2529	CAP SCREW	3/8" NC x 2 1/2"		4
L	81-2539	CAP SCREW	3/8" NC x 5"	MOUNTING BOLT	4
M	81-2638	FLAT WASHER	3/8"		1
N	81-2509	CAP SCREW	5/16" NC x 1"		1
O		NUT	5/16"		1
P	51-2801	SWITCH ROD	5/16" x 39"	CENTER FRAME UNITS	
R	51-2802	SWITCH ROD	5/16" x 34"	PERIMETER FRAME UNITS	

IMPORTANT

KEEP DECK BOLTS
TIGHT AT ALL TIMES!
LOOSE BOLTS WILL
DAMAGE YOUR DECK

TORQUE 3/8" TO 35 FT/LBS
TORQUE 1/2" TO 55 FT/LBS

WARRANTY

Hallco Manufacturing Company, Incorporated warrants each of the Hallco Live Floor systems sold by it or any of its authorized distributors, when properly assembled and installed, to be free from defects in material and workmanship under normal use and service. This warranty expressly excludes deck seal, when used. The manufacturer's obligation under this warranty being limited to repairing or replacing, as herein provided, at its option, any part or parts of said system manufactured by Hallco Manufacturing Company, Incorporated which within twelve (12) months after delivery shall be found to the manufacturer's satisfaction to be defective upon examination by it, provided such part or parts shall be returned, at customer's expense, to manufacturer's factory at 6605 Ammunition Road, Tillamook, Oregon 97141.

This warranty shall not apply to any unit which has been subject to misuse, negligence or accident, or which shall have been altered or repaired outside the factory in anyway, which in the manufacturer's judgment might affect the reliability of said systems.

This warranty is mad expressly in lieu of any other warranties, expressed or implied, including any implied warranty of merchantability or fitness for any particular purpose, and of any other obligation or liability on the part of the manufacturer including, without limitation of the foregoing, consequential and incidental damages. The manufacturer neither assumes nor authorizes any person to assume for it any other liability in connection with the sale of such new Hallco Live Floor systems.

NOTES:

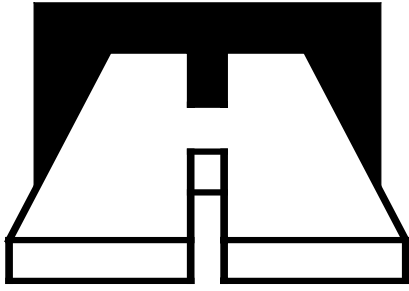

HALLCO FLOOR SYSTEMS

ALWAYS TAKING THE FIRST STEP

TM

Corporate Office:

Hallco Mfg. Co., Inc.

P.O. Box 505

1900 Hallstrom Rd.

Tillamook, Oregon 97141

Phones: 888-412-5092 503-842-8746 Fax: 503-842-4866

Manufacturing Plant:

Hallco Mfg. Co., Inc.

P.O. Box 505

6605 Ammunition Rd.

Tillamook, Oregon 97141

Phones: 800-542-5526 503-842-8886 Fax: 503-842-8499

East Coast Distribution Warehouse:

Hallco Mfg. - East

606-B Performance Road

Mooreville, North Carolina 28115

Phones: 800-230-0190 704-662-9615 Fax: 704-662-9603

Central Distribution Warehouse:

Hallco Mfg. - Texas

8276 Hwy 16 North

Poteet, TX. 78065

Phones: 877-425-5261 830-742-8441 Fax: 830-742-8682